



XD1-T – Transformer differential protection relay

(March 2008)

Manual XD1-T (Revision New)

Woodward Governor Company reserves the right to update any portion of this publication at any time. Information provided by Woodward Governor Company is believed to be correct and reliable. However, no responsibility is assumed by Woodward Governor Company unless otherwise expressly undertaken.

© Woodward 1994-2008

Contents

1.	Application and features	4
2.	Design	5
3.	Working Principle.....	6
3.1	Operating principle of the differential protection.....	6
3.2	Balancing of phases and current amplitudes	7
3.3	Transformer regulation steps	7
3.4	Working principle of the C.T. saturation detector SAT	8
3.5	Transformer inrush.....	10
3.6	Block diagram	12
4.	Operation and settings	13
4.1	Parameter setting by using DIP-switches.....	14
4.2	Setting recommendations	14
5.	Relay testing and commissioning	16
5.1	Power on	16
5.2	Secondary injection test.....	16
5.2.1	Trip level I_{d1}	17
5.2.2	Inrush blocking	17
5.3	Primary test.....	18
5.3.1	Adjustment of the interposing C.T.s	18
5.3.2	Function test.....	19
6.	Technical data	20
6.1	Relay case	20
6.2	Technical Data	21
7.	Order form.....	25

1. Application and features

Power transformers are classified as one of the most valuable equipments in a power system, hence their protection is of very high importance. The transformer differential protection provides fast tripping in case of a fault - before severe damage spreads out.

The XD1-T relay is a strict selective object protection for two-winding transformers. Within a very short time this relay detects faults occurring within the zone to be protected and which require immediate tripping and isolation of the transformer. Such faults are:

- short circuits between turns, windings and cables in-side the transformer housing
- earth faults inside the housing
- short circuits and earth faults outside the housing but within the protected zone (e.g. at bushings or supply lines).

The XD1-T is also able to detect other operational conditions (e.g. faults outside the protected zone, circuit closing etc.) i.e. it does not issue tripping commands for faults or any other transient phenomena outside the protected zone.

Additional to the transformer differential protection an overcurrent relay as backup protection is recommended. For this application we offer the relays MRI1/IRI1/XI1.

The relay XD1-T of the PROFESSIONAL LINE has the following special features:

- Fault indication via LEDs
- Extremely wide operating ranges of the supply volt-age by universal wide-range power supply
- Very fine graded wide setting ranges
- Extremely short response time
- Compact design by SMD-technology
- Very low C.T. burden
- Adjustment to transformation ratio and connection groups without external interposing C.T.s
- Two stage tripping characteristic
- Galvanic insulation between all independent inputs
- Additional printed circuits "Saturation Detection" can be retrofitted at a later time
- Self-supervision of stabilization circuits
- Wide setting ranges

2. Design

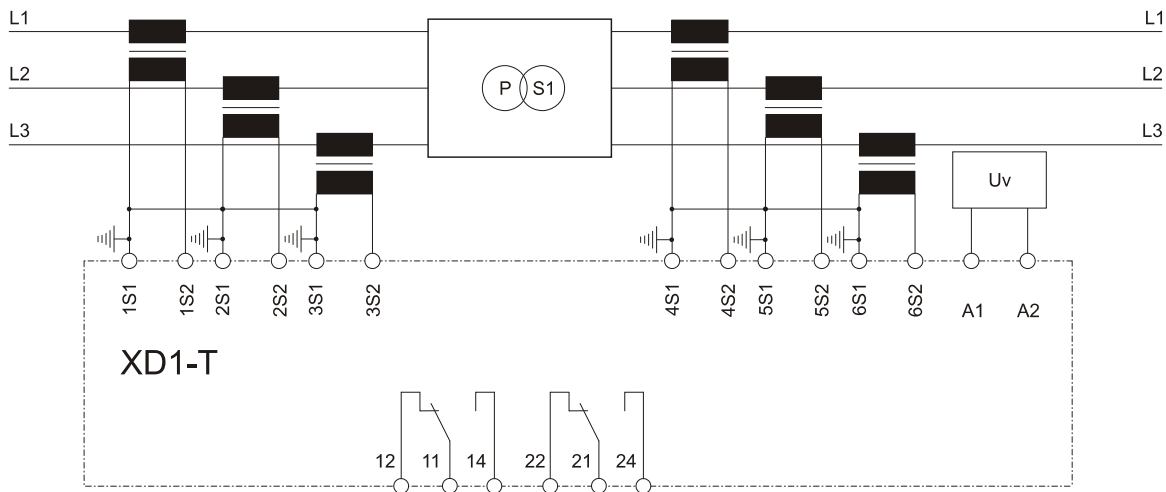

Figure 2.1: Connection diagram

Analog inputs

The analog secondary currents of the HV side are fed to the protection relay via terminals 1S1 - 3S2 and the secondary currents of the LV side via terminals 4S1 - 6S2.

Auxiliary voltage supply

Unit XD1-T needs a separate auxiliary voltage supply. Therefore a DC or AC voltage must be used. Unit XD1-T has an integrated wide range power supply. Voltages in the range from 19 - 390 V DC or 35 - 275 V AC can be applied at connection terminals A1 and A2.

Contact positions

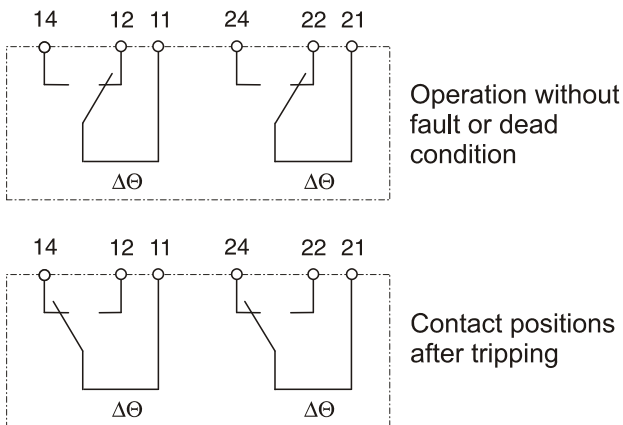

Figure 2.2: Contact positions of the output relays

3. Working Principle

3.1 Operating principle of the differential protection

The fundamental operating principle of transformer differential protection is based on comparison of the transformer primary and secondary winding currents. For an ideal transformer, having a 1:1 ratio and neglecting magnetizing current, the currents entering and leaving the transformer must be equal.

During normal operation or when a short circuit has occurred outside the protected zone, the C.T. secondary currents in the differential circuit neutralize each other. In case that a differential current I_d occurs, a fault in the transformer is detected.

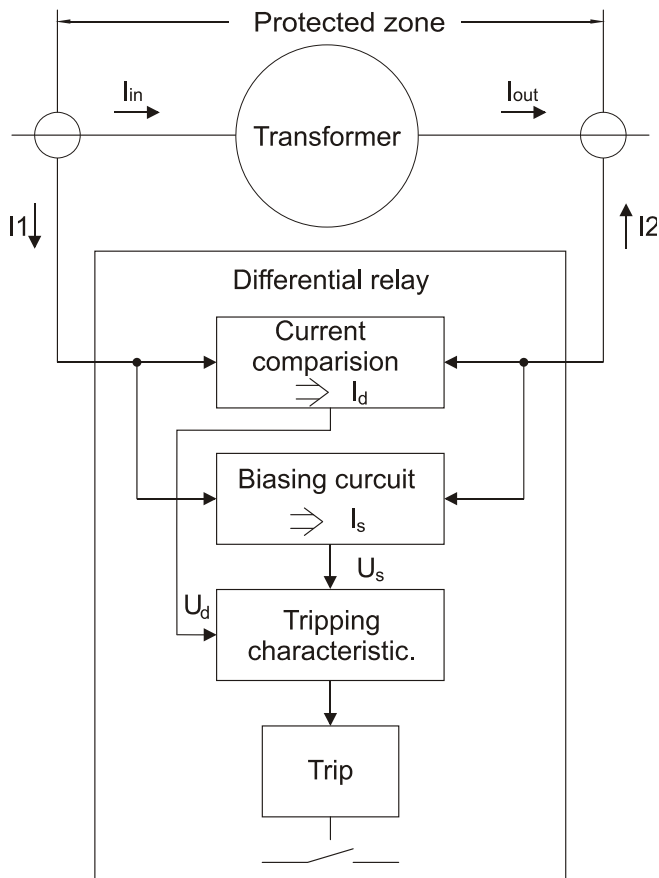

Figure 3.1: General arrangement of differential protection:
 I_d = differential (tripping) current
 I_s = stabilizing current

Because of different problems, however, in practice measures for adaption and stabilization have to be taken to ensure trouble-free function of the transformer differential protection:

- Due to possible mismatch of ratios among different current transformers.
- Phase differences between primary and secondary side, caused by transformer vector groups, have to be duly considered.
- Switching operations in the grid have to be recognized as such.
- Inrush currents of the transformer must not result in mal-operation.

3.2 Balancing of phases and current amplitudes

First of all the phase difference between primary and secondary side, which is caused by transformer vector groups, has to be compensated and the current amplitudes to be balanced. Unlike most other differential protection relays available, this scheme includes inter-posing C.T.s integrated in the differential relay, extra interposing C.T.s are not required.

Connection of interposing C.T.s is dependent on the vector group of the power transformer. For instance, for transformers with star (Y) windings the interposing C.T.s are connected in delta (Δ) to reject residual currents (i.e. currents flowing to the transformer due to an earth fault outside the protected zone and which would produce a differential current I_d) and to prevent mal-operation of the differential protection.

3.3 Transformer regulation steps

The XD1-T can universally be used i.e. also for regulating transformers with an adjustable transformation ratio to stabilize voltage fluctuations of the supplying systems. Since, however, as a result of vector group balance and transformation ratio balance the differential protection is adjusted to the nominal transformation ratio of the transformer, an apparent differential current I_d arises proportionally to the flowing load current. Mal-operation of the protection is prevented by the load-proportional stabilizing current I_S .

3.4 Working principle of the C.T. saturation detector SAT

With many transformer differential protection systems, relay instability may cause to trip if the main current transformers saturate. In the transient condition of saturation the C.T.s on both ends of the protected zones do not produce the correct secondary current according to the primary current. The differential relay measures a differential current on the secondary C.T. side which is not present on the primary side. Hence a nuisance tripping might occur.

Such transient phenomena causing C.T. saturation may occur due to:

- Heavy through faults (external short circuit)
- Starting of big motors
- Magnetizing inrush currents of transformers
- Internal faults

The figure 3.2 explains the saturation of the C.T. core due to a short circuit current. In the instant of a short circuit often a DC-component is present in the current. The high primary current induces a flux in the C.T. core, reaching the saturation level. The iron-core retains the high flux level even after the primary current falls to zero. In the time periods of saturation the C.T. does not transform the primary current to the secondary side but the secondary current equals zero.

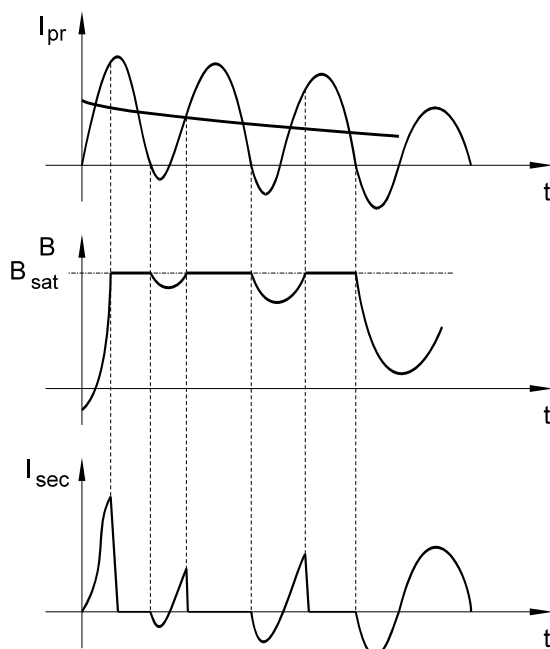

Figure 3.2: *Current transformer saturation*
 a) *Primary current with DC offset*
 b) *Core flux density*
 c) *Secondary current*

Dissimilar saturation in any differential scheme will produce operating current.

Figure 3.3 shows the differential measurement on the example of extremely dissimilar saturation of C.T.s in a differential scheme. Fig. 3.3 shows the secondary current due to C.T. saturation during an transformer fault (internal fault). The differential current i_d represents the fault current. The differential relay must trip instantaneously.

Figure 3.3 shows the two secondary currents in the instant of an heavy external fault, with current i_1 supposed to C.T. saturation, current i_2 without C.T. saturation.

The differential current i_d represents the measured differential current, which is an operating current. As this differential current is caused by an external fault and dissimilar saturation of the two C.T.s, the differential relay should not trip.

Left Single end fed: i_1 = secondary output current from saturated C.T. (theoretical)
 $i_2 = 0$; Internal fault fed from side 1 only
 i_d = measured differential current

Right External fault: i_1 as in fig. 3.3 for an internal fault
 i_2 normal current from C.T. secondary on side 2
 The wave forms for the differential current i_d for internal and external faults are seen to be different for the two cases considered.

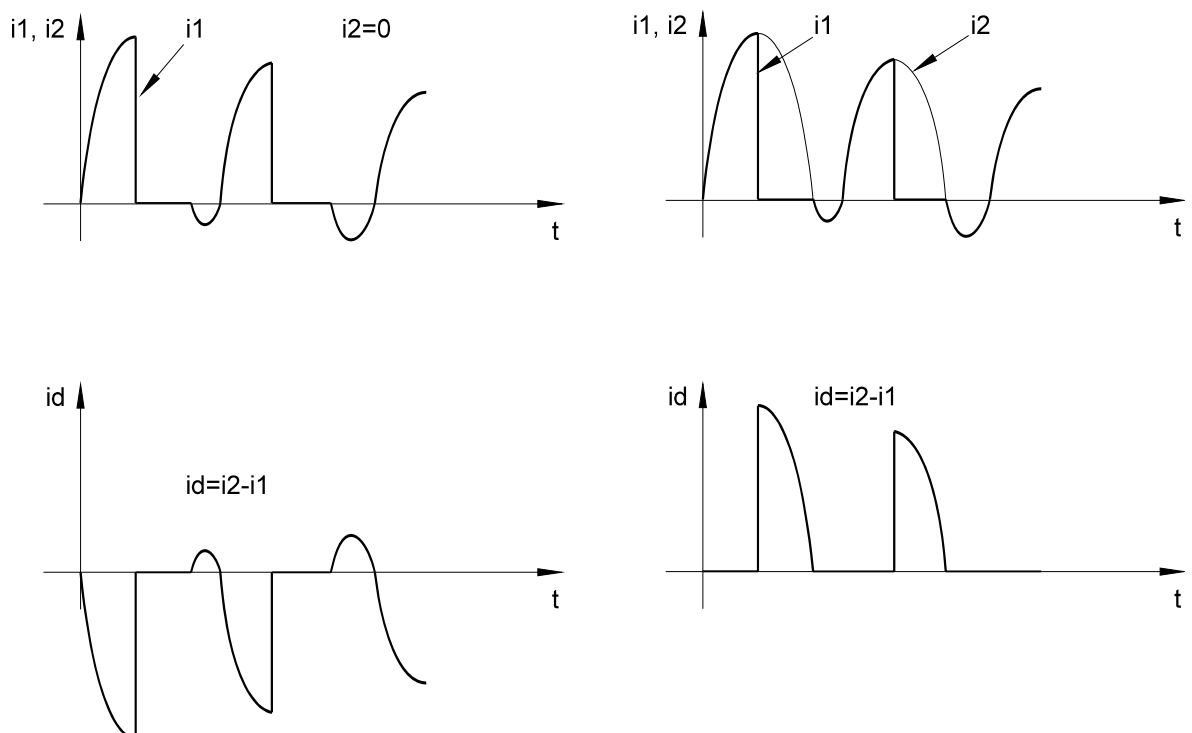

Figure 3.3: Current comparison with C.T.s saturated by DC offset in fault current wave form internal fault

The saturation detector SAT analyses the differential current of each phase separately. The SAT module differentiates the differential current and detects:

- Rate of change of differential current $d(i_d)/dt$
- Sign of $d(i_d)/dt$
- Internal/external fault
- Duration of saturation, within one cycle
- DC or AC saturation

The instant of an extreme rate of change of differential current $d(i_d)/dt$ clearly marks the beginning of a C.T. saturation.

The sign of this $d(i_d)/dt$ value distinguishes the internal fault from an external fault. One detected extreme $d(i_d)/dt$ value per cycle indicates a saturation due to DC-current contents. Whereas two extreme $d(i_d)/dt$ values per cycle indicate a C.T. saturation caused by a high alternating current.

The logic control evaluating above information derives.

Only external faults lead to blocking of the trip circuit:

- In case of detected DC-current saturation the differential current measurement is blocked completely until: the transient condition ends, or an internal fault is detected (instantaneously), or AC-current saturation is detected.
- In case of detected AC-current saturation only the time periods of saturation are blocked during one cycle. This means that even under severe saturation the differential relay evaluates the differential current in "sound" time periods. This is a major advantage to relays solely applying harmonic filters for saturation detecting.
- All detected transient phenomena change the tripping characteristic to the "coarse tripping characteristic" (pl. ref. to Technical Data).

This logic control circuit provides a continuous self diagnostic, limiting any blocking function to maximum of 1.7 seconds.

This approach has several advantages. For example, if a C.T. saturated as a result of an external fault, the relay remains stable because the measuring system recognizes the differential current is due to C.T. saturation arising from a fault outside the protected zone. However, if an internal fault occurs, this is immediately recognized, blocking is overridden and the relay trips immediately.

Similarly, if a fault occurs during magnetizing inrush of a transformer this is immediately detected and the differential relay operates correctly tripping the transformer.

3.5 Transformer inrush

When a transformer is first energized, a transient inrush current flows. This inrush current occurs only in the energized winding and has no equivalent on the other side of the transformer. The full amount of inrush current appears as differential current and would cause the differential relay to trip if there is no stabilization against the inrush phenomenon.

Typically the inrush current contains three components that distinguish it from other fault currents:

- **The DC-component:**
The DC-component is present at least in one phase of the inrush current, depending on the instant of energizing.
- **The second harmonic:**
The second harmonic is present in all inrush currents due to uni-directional flux in the transformer core.
- **The fifth harmonic:**
The fifth harmonic is present when the transformer is subjected to a temporary overvoltage.

The filter module "SAT" detects not only C.T. saturation due to external faults but also the inrush current of the transformer to be protected.

The differential current i_d of each phase is analyzed separately. The signal of i_d passes a filter arrangement detecting transient conditions due to the DC-component, the second harmonic and the fifth harmonic.

Thus all three components are used for detecting an in-rush current. The limits for blocking of the differential protection are:

DC-component:	20%...60% of I_d
2nd harmonic:	20%...50% of I_d
5th harmonic:	10%...25% of I_d

The restraining influence, resp. the blocking depends on the combination of the three components. If only a single component is present, the highest value applies. If a mixture of all three components is present, the lowest values apply.

With this combined measurement of the three restraining components XD1-T achieves:

- Reliable inrush stabilization
- Fast tripping if the incoming transformer is defective
- Restraining feature against C.T.-saturation.

Whereas a complete blocking of the protection is only performed during the first energizing of the transformer, the harmonic content supervision restrains during normal operation against phenomena like C.T. saturation. This means that internal faults will be detected instantaneously (ms), whereas external faults do not cause tripping.

The inrush blocking is stopped when:

- The differential current I_d falls below the tripping characteristic, or
- the differential current I_d shows an internal fault, according to the harmonic content, or
- the differential current I_d exceeds 15 x nominal current, or
- a fixed period of time has elapsed.

The basic relay version without module "SAT" does not provide the harmonic restrain feature.

For applications on bigger transformers or for generator-transformer protection we recommend the use of module "SAT".

3.6 Block diagram

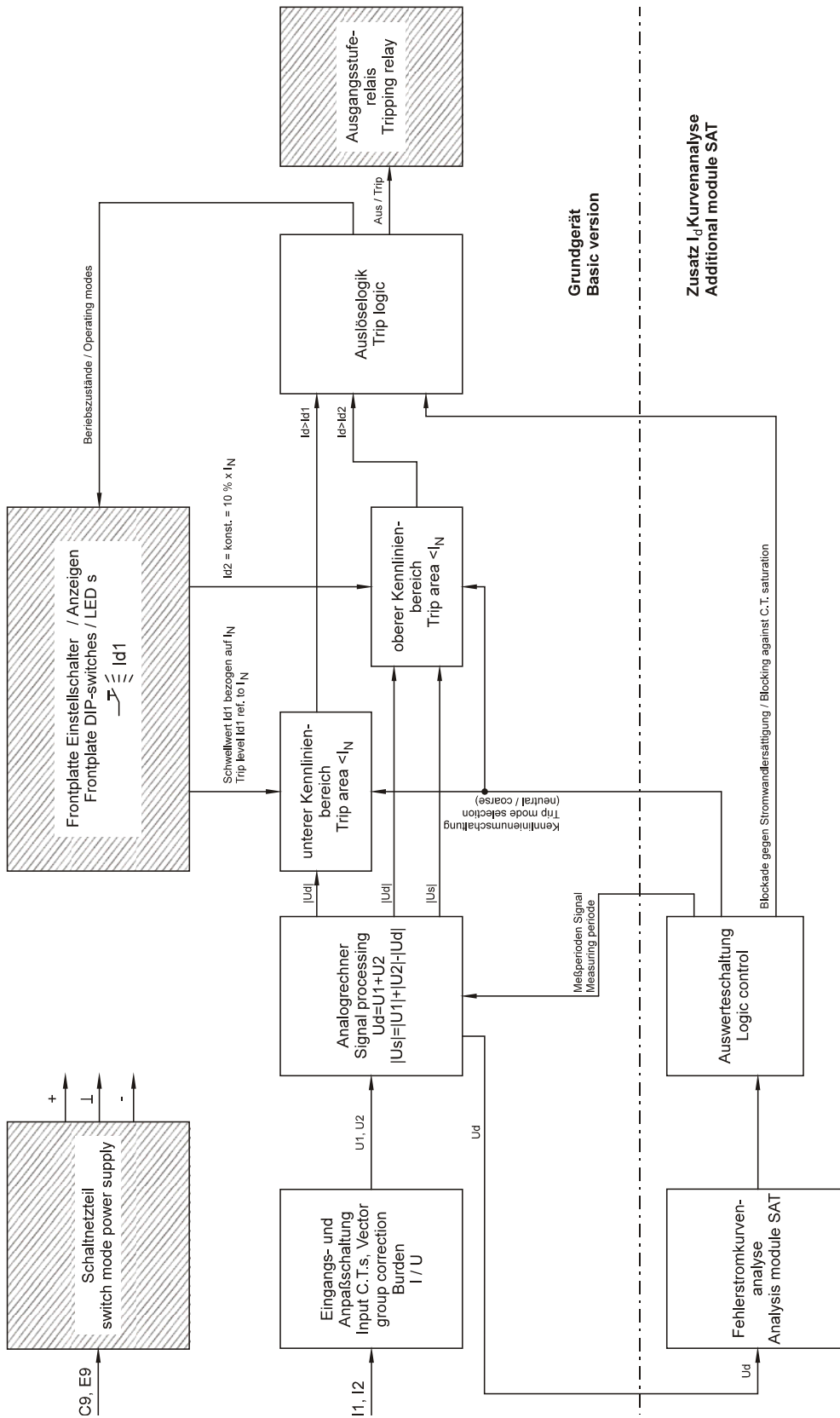

Figure 3.4: Block diagram

4. Operation and settings

All operating elements needed for setting parameters are located on the front plate of the XD1-T as well as all display elements.

Because of this all adjustments of the unit can be made or changed without disconnecting the unit off the DIN-rail.

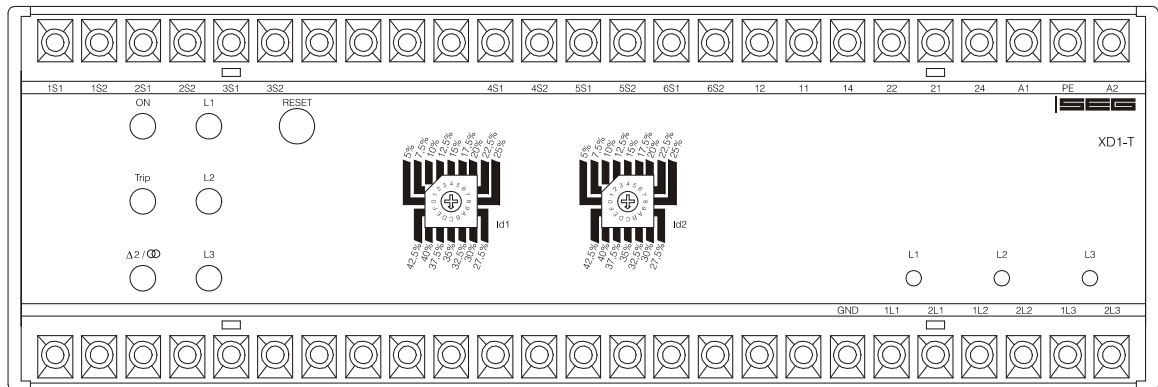

Figure 4.1: Front plate XD1-T

For adjustment of the unit the transparent cover has to be opened as illustrated. Do not use force! The transparent cover has two inserts for labels.

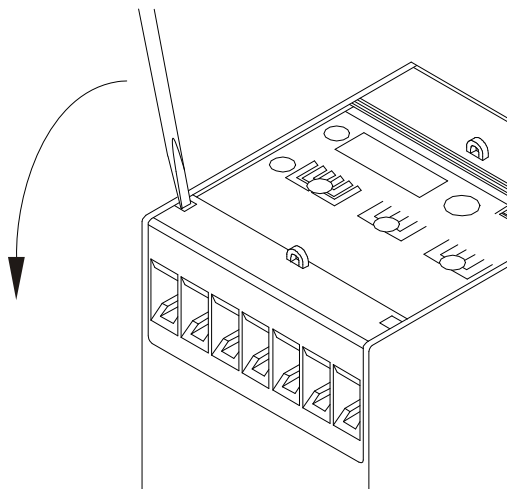

Figure 4.2: How to open the transparent cover

LEDs

LED „ON“ is used for display of the readiness for service (at applied auxiliary voltage U_v). LEDs L1, L2, L3 and TRIP are provided for fault indication. LED $\Delta 2/\infty D$ indicates inrush stabilization. For relays with an additional SAT module, changeover to the coarse measuring element is indicated.

Reset push-button

The Reset push-button is used for acknowledgement and resetting the LEDs after tripping.

Potentiometer

The 3 potentiometer on the lower right side of the front plate are provided for adjustment of the interposing C.T.s (refer to chapter 5.3.1).

4.1 Parameter setting by using DIP-switches

The XD1-T provides two DIP-switches for the adjustment of the tripping characteristic:

I_{d1} represents the setting for the tripping area below nominal current. The I_{d1} setting relates to the nominal current of the relay and is independent of the through current.

I_{d2} represents the setting for the tripping area above nominal current. The I_{d2} setting relates to the "stabilizing current I_s ". Whereas I_s is the current flowing through the protected zone. This biasing area is important for external faults. The higher the current due to an external fault, the higher is the biasing influence.

On through faults, large differential currents may be produced by the transformer tap changer or due to mismatching of the current transformers. The biased slope characteristic prevents incorrect operation of the relay under these conditions.

With the additional module SAT the tripping characteristic changes to "coarse" in case of detected transient phenomena, as explained above. The fixed tripping values for the coarse measurement are:

$$I_{d1} = 100 \% I_N$$

$$I_{d2} = 60 \% I_s$$

4.2 Setting recommendations

The tripping characteristic should be selected according to the known mismatch of the secondary currents fed to the relay plus a safety margin of 10 to 15 %. This setting avoids mal-operation caused by normal load conditions.

Mismatch of the currents may be produced by:

- Ratio error and phase shifting of the C.T.s. E.g.: For protection C.T.s of 10P20 rating the ratio error at nominal current is max. 3 %. At 20 times nominal current the ratio error reaches 10 %.
- Load tap changer (LTC). The automatic LTC may vary the ratio of the protected transformer as much as $\pm 10\%$. This causes a current mismatch of the same amount.
- The deviation resulting from the transformer vector group should be compensated by the internal converters and their burden.

Considering the example above, both settings Id1 and Id2 should be set to:
 3% + 3% for C.T. errors
 10% for transformer step changer
 15% safety margin

Arrives to a setting of 31%. The nearest possible setting is 30%. Hence both DIP-switches should be set to 30%. The pictures below show the DIP-switch setting as well as the actual tripping characteristic.

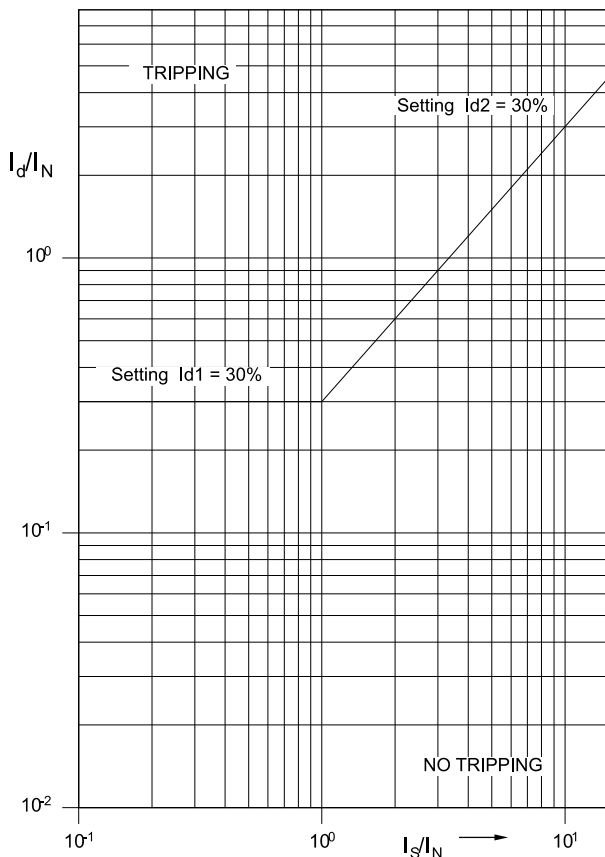

Figure 4.3: Adjustment example

For this DIP-switches for Id1 and Id2 have to be in the following positions:

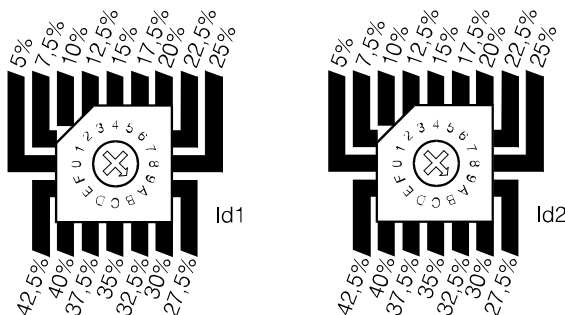

Figure 4.4: Adjustment of step switches

5. Relay testing and commissioning

Correct connection of primary and secondary side of the C.T.s as well as the correct connection and adjustment of the internal matching C.T.s are the condition for a perfect service of the differential relay.

Therefore please observe:

The order form should be filled with great care. The transformer differential relay will be pre-adjusted at SEG according to the order form.

When taking the relay into service the commissioning checks explained below should be followed. The test instructions following below help to verify the protection relay performance before or during commissioning of the protection system. To avoid a relay damage and to ensure a correct relay operation, be sure that:

- the auxiliary power supply rating corresponds to the auxiliary voltage on site.
- the rated current correspond to the plant data on site.
- the current transformer circuits are connected to the relay correctly. Please pay special attention also to the primary connections of the C.T.s.
- the input circuits and output relay circuits are connected correctly.

5.1 Power on

NOTE!

Prior to switch on the auxiliary power supply, be sure that the auxiliary supply voltage corresponds with the rated data on the type plate.

When the auxiliary supply is switched on please observe that the LED "ON" is alight.

5.2 Secondary injection test

Test equipment:

- One adjustable current source up to two times nominal current of the relay
- Ammeter with class 1
- Auxiliary supply source corresponding with the nominal auxiliary supply of the relay.
- Power diode (10 A)
- Switching device
- Test leads and tools

NOTE!

Before this test is initiated by means of secondary current, it must be ensured that the relay cannot cause any switching actions in the system (shut-down risk).

5.2.1 Trip level I_{d1}

Inject a current into each current input according to the test circuit below and check the current value at which a trip occurs. The tripping values should correspond to:

- For the relay side connected to the star-side of the transformer: 1.73 times the setting of I_{d1} .
- For the relay side connected to the delta side of the transformer: 1.0 times the setting of I_{d2} .

The difference of tripping levels is explained by the internal matching C.T.s. The star-side matching C.T.s are internally connected in delta and transform the current to a value 0.58 times the input current.

The delta side matching C.T.s are internally connected in star. Hence the transformation ratio is 1.

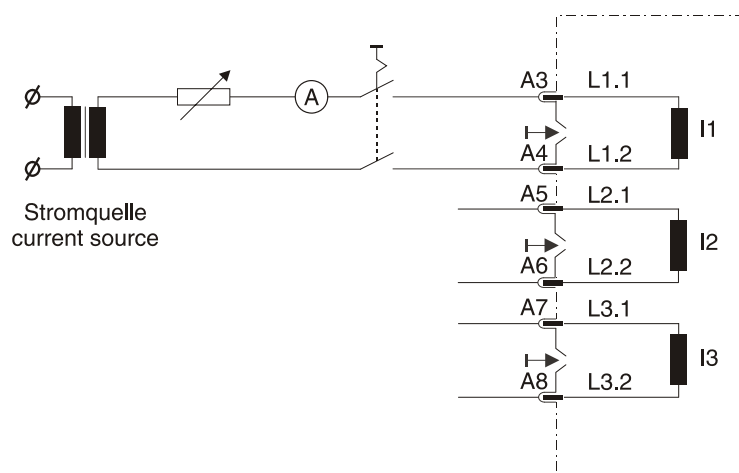

Figure 5.1: Test circuit

5.2.2 Inrush blocking

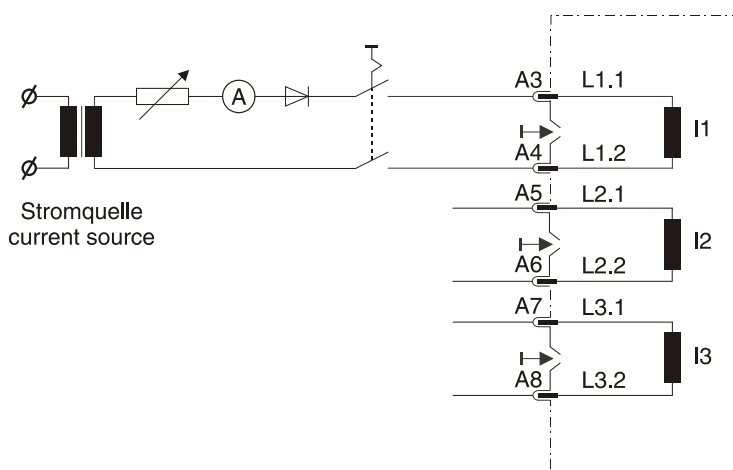

Figure 5.2: Test circuit for inrush blocking

Adjust the input current to app. 1.5 times nominal current. Switch off the current. Switch the current on with the same adjustment. Observe that the inrush blocking LED lights up and no trip occurs. Observe that after a blocking time of 3.5 s the LED extinguishes and a trip occurs. This is caused by the maximum blocking time supervision. Switch the current off. If saturation detector SAT is used the maximum blocking time is reduced to 1.7 s.

5.3 Primary test

The test of the correct connection of the main C.T.s and the correct matching of the internal measuring values can only be done with the transformer in service.

A minimum load of app. 50 % of the transformer load is recommended to avoid mal-interpretation of measuring values. At low currents the magnetizing current of the transformer has a high influence on the test results.

Make sure that the trip circuit of the differential relay is blocked and cannot cause unwanted tripping. On the other hand a backup protection, like an overcurrent relay, must protect the transformer in case of faults !

5.3.1 Adjustment of the interposing C.T.s

The correct connection and accurate adjustment of the C.T.s can be checked with a voltmeter. For this 7 terminals are provided at the lower terminal strip. The associated adjustment potentiometers are arranged above these terminals. Differences of the main C.T.s up to 15 % I_N can be adjusted by the potentiometers.

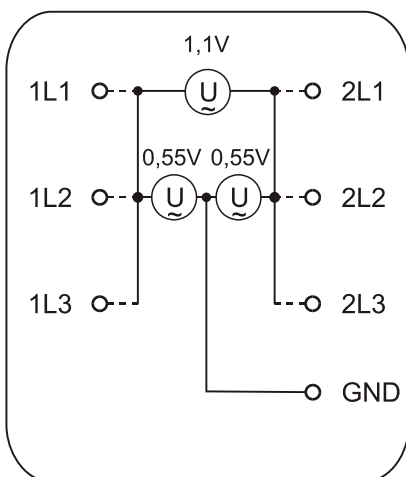

Figure 5.3: Connection of voltmeter

Information about measuring results can be found on the following table.

a)	Measuring 1 (1L1 - GND) Measuring 2 (2L1 - GND) Measuring 3 (1L1 - 2L1)	550 mV 550 mV 1100 mV	Correct connection
b)	Measuring 1 (1L1 - GND) Measuring 2 (2L1 - GND) Measuring 3 (1L1 - 2L1)	550 mV 550 mV 0 mV	Current flow of a C.T. (S1 and S2) is mixed-up
c)	Measuring 1 (1L1 - GND) Measuring 2 (2L1 - GND) Measuring 3 (1L1 - 2L1)	550 mV 550 mV 550 mV	Phase position mixed-up (e.g. one current from phase L1, the other one from phase L2)
d)	Measuring 1 (1L1 - GND) Measuring 2 (2L1 - GND) Measuring 3 (1L1 - 2L1)	550 mV 550 mV 950 mV	Current flow and phase position of a C.T. is mixed-up

Table 5.1: Measuring results

The internal measuring voltages proportional to the input currents may be measured as follows. The measuring instrument should be a digital multimeter set to AC-voltage measurement, range 2.0 V. The readings stated below refer to nominal current of the transformer (referring to the order form). Any current value below may be calculated proportionally.

Please also note that due to the C.T. errors and the transformer magnetizing current the measured values might deviate up to 10% from the theoretical values.

Nominal load current of the transformer is generally transformed to the internal measuring voltage of 550 mV AC. Both amplitudes of the measuring voltages of one phase, e.g. 1L1 and 1L2, should be equal. The phase angle of the voltages of one phase, e.g. 1L1 and 1L2, must be 180 degrees. A slight deviation might be caused by the magnetizing current of the transformer.

Hence the differential measurement in one phase, e.g. lead 1 connected to 1L1 and lead 2 connected to 2L1, must read twice the value of the measurement 1L1 to GND.

In case there are deviations from the expected value please check all wiring to the relay. This check must include the connection of the primary C.T. side and the secondary side. In most cases a wrong connection of the C.T.s is the reason for mal-operation of the differential protection. If all connections are correct and the internal measuring value still shows deviations from the expected values, please check if the transformer group given on the type plate corresponds to the transformer vector group.

If the single ended measurements (e.g. 1L1 - GND) differ within one phase, e.g.:

1L1 - GND:	400 mV
2L1 - GND:	600 mV
1L1 - 2L1:	1000 mV

but the differential measurement equals the sum of both the deviation may be balanced using the concerned potentiometer on the front plate.

5.3.2 Function test

Attention!

Disconnect all leads for adjusting the interposing C.T.s and perform the following function test:

Load the transformer with minimum 50% load. Assure that the tripping of the transformer C.B. does not cause unwanted damages (blackout).

To operate the differential relay use a shorting link between one of the phase terminals and GND, e.g. connect 1L1 to GND. The relay should trip immediately. If no trip occurs, make sure that the load current exceeds the set value of Id1.

6. Technical data

6.1 Relay case

Relay XD1-T is designed to be fastened onto a DIN-rail acc. to DIN EN 50022, the same as all units of the PROFESSIONAL LINE.

The front plate of the relay is protected with a sealable transparent cover (IP40).

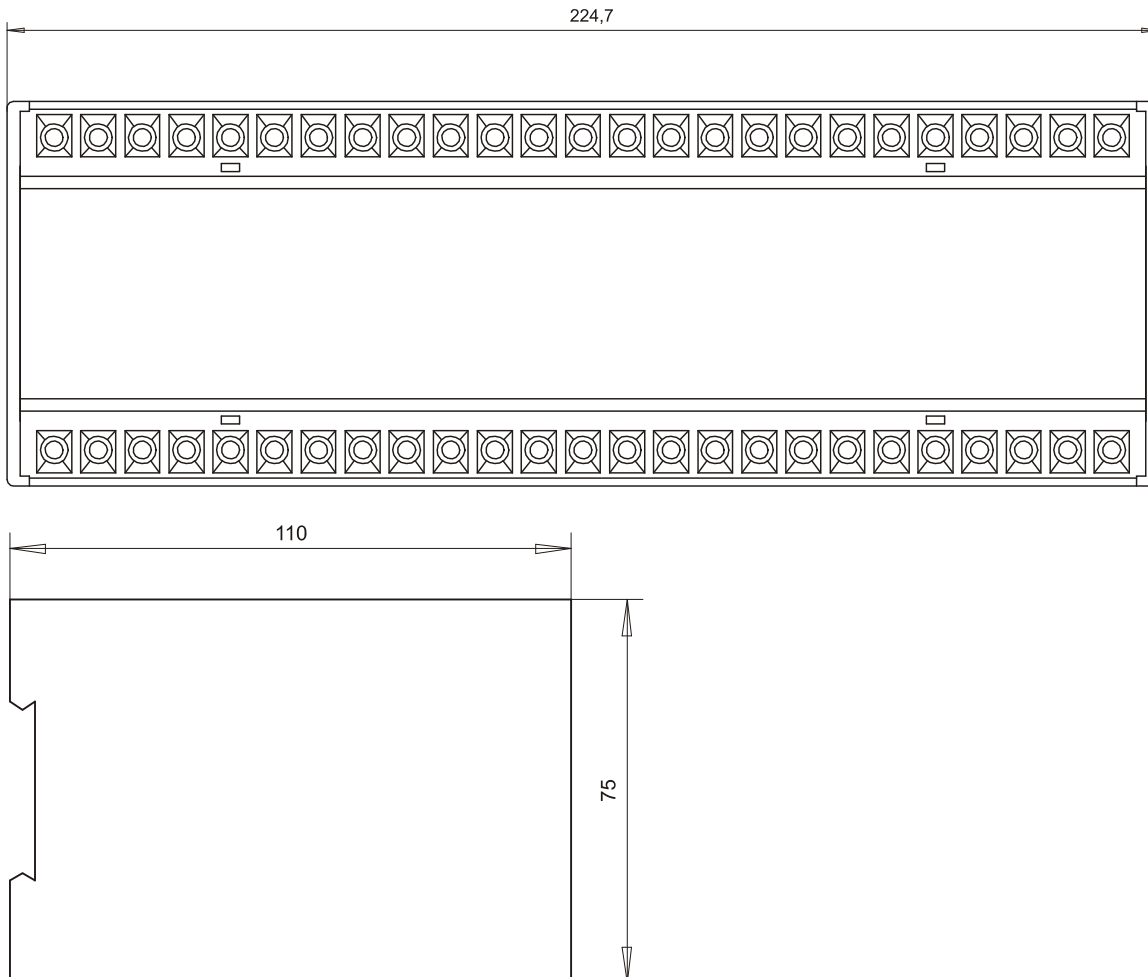

Figure 6.1: Dimensional drawing

Connection terminals

The connection of up to a maximum $2 \times 2.5 \text{ mm}^2$ cross-section conductors is possible. For this the transparent cover of the unit has to be removed (see para. 4).

6.2 Technical Data

Measuring input

Rated data:

Rated current I_N :	1 A / 5 A
Rated frequency f_N :	50 - 60 Hz
Power consumption in current circuit:	at $I_N = 1$ A <0.1 VA
	at $I_N = 5$ A <0.5 VA

Thermal withstand capability

in current circuit:	dynamic current withstand (half-wave)	250 x I_N
	for 1 s	100 x I_N
	for 10 s	30 x I_N
	continuously	4 x I_N

Auxiliary voltage

Rated auxiliary voltages U_H :	35 - 275 V AC (f = 40 - 70 Hz)
	19 - 390 V DC

General data

Dropout to pickup ratio:	>97%
Returning time:	<50ms
Returning time after tripping:	100ms \pm 10ms
Minimum operating time:	40ms

Output relays

The output relays have the following characteristics:

Maximum breaking capacity:	250 V AC/1500 VA / continuous current 6 A
----------------------------	-------------------------------------------

For DC-voltage:

	ohmic	L/R = 40 ms	L/R = 70 ms
300 V DC	0,3 A/90 W	0,2 A/63 W	0,18 A/54 W
250 V DC	0,4 A/100 W	0,3 A/70 W	0,15 A/40 W
110 V DC	0,5 A/55 W	0,4 A/40 W	0,20 A/22 W
60 V DC	0,7 A/42 W	0,5 A/30 W	0,30 A/17 W
24 V DC	6,0 A/144 W	4,2 A/100 W	2,50 A/60 W

Max. rated making current:	64 A (VDE 0435/0972 and IEC 65/VDE 0860/8.86)
Making current:	min. 20 A (16 ms)
Mechanical life span:	30 x 10 ⁶ operating cycles
Electrical life span:	2 x 10 ⁵ operating cycles at 220 V AC / 6 A
Contact material:	silver cadmium oxide (AgCdO)

System data

Design standard:	VDE 0435, T303; IEC 255-4; BS142
------------------	----------------------------------

Specified ambient service

Storage temperature range:	- 40°C to + 85°C
Operating temperature range:	- 20°C to + 70°C

Environmental protection class F
as per DIN 40040 and per
DIN IEC 68 part 2-3:

relative humidity 95 % at 40°C for 56 days

Insulation test voltage, inputs and outputs between themselves and to the relay frame as per VDE 0435, part 303 and IEC 255-5:	2.5 kV (eff.), 50 Hz; 1 min
Impulse test voltage, inputs and outputs between themselves and to the relay frame as per VDE 0435, part 303 and IEC 255-5:	5 kV; 1.2/50 μ s; 0.5 J
High frequency interference test voltage, inputs and outputs between themselves and to the relay frame as per IEC 255-6:	2.5 kV/1MHz
Electrostatic discharge (ESD) test as per VDE 0843, part 2 IEC 801-2:	8 kV
Radiated electromagnetic field test as per VDE 0843, part 3 IEC 801-3:	electric field strength 10 V/m
Electrical fast transient (Burst) test as per VDE 0843, part 4 IEC 801-4:	4 kV/2.5 kHz, 15 ms
Radio interference suppression test as per DIN/VDE 57871:	limit value class A
Mechanical tests:	
Shock:	class 1 as per DIN IEC 255 part 21-2
Vibration:	class 1 as per DIN IEC 255 part 21-1
Degree of protection:	IP40 at closed front cover
Weight:	ca. 1.5 kg
Mounting position:	any
Overvoltage class:	III
Relay case material:	self-extinguishing

Tripping characteristics

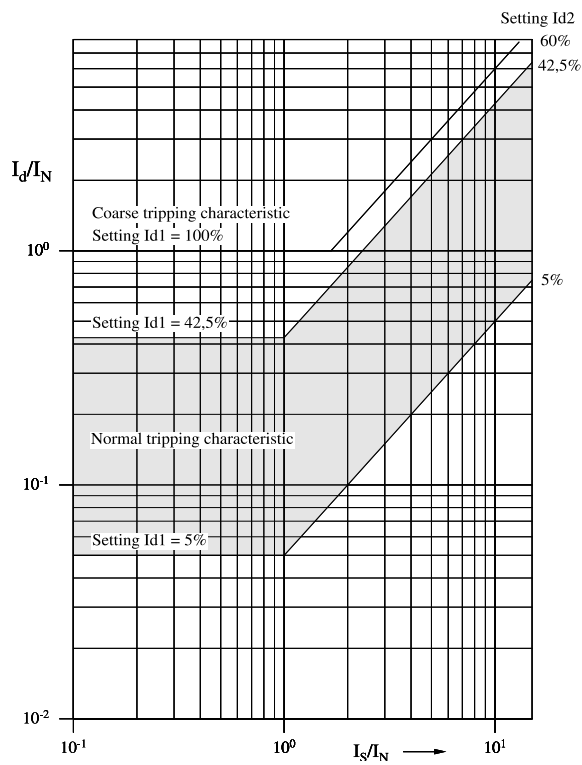

Figure 6.2: Tripping range

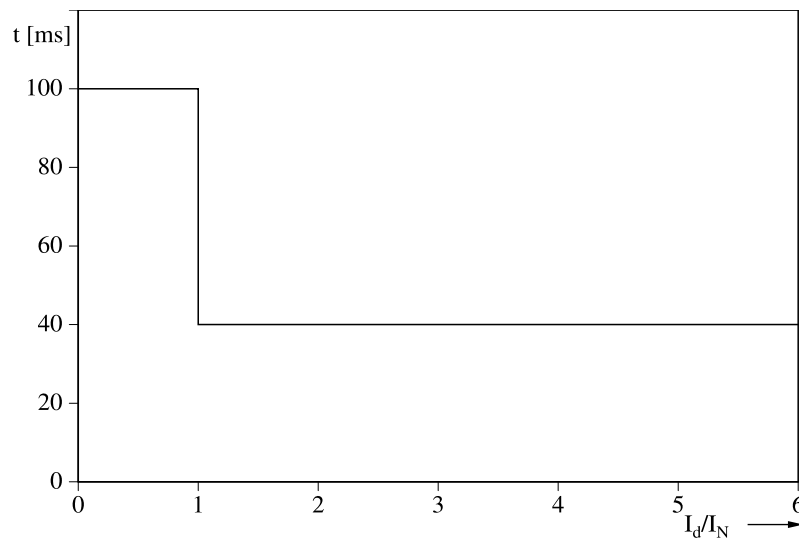

Figure 6.3: Tripping time

Accuracy details

for $I_S < I_N$:

$$f = \left| \frac{I_{dtrip} - I_{dset}}{I_N} \right| \cdot 100\%$$

for $I_S \geq I_N$:

$$f = \left| \frac{I_{dtrip} - I_{dset}}{I_S} \right| \cdot 100\%$$

where

e = relative error
 I_S = stabilizing current
 I_N = rated current
 I_{dtrip} = measuring differential current which results in tripping
 I_{dset} = differential current setting

Note:

The accuracy details quoted are based on interposing current transformer with exact correction ratio.

Accuracy at reference conditions:

- Temperature range -5°C...40°C e ≤ 2.5 %
- Frequency range 50 Hz...60 Hz: e ≤ 2.5 %

If the operating temperature or frequency are outside the ranges quote, additional errors are:

- Temperature range -20°C...70°C: e_{add} < 2.5 %
- Frequency range 45 Hz...66 Hz: e_{add} = 1 %

7. Order form

Differential protection relay		XD1-				
Transformer protection (two windings)			T			
Primary rated current	1 A			1		
	5 A			5		
Secondary rated current	1 A				1	
	5 A				5	
none						*
Latching relay and manual reset						SP
none						*
Extra equipment for reliable functioning during CT saturation ¹						SAT

* Please leave box empty if option is not desired

Transformer rated capacity				
		MVA		
Vector group				
Voltage	High voltage side			kV ± %
	Low voltage side			
Current transformer ratio	High voltage side		/	
	Low voltage side		/	
Rated current	High voltage side		/	
	Low voltage side		/	

Important instruction !

In order to ensure the balancing of the transformer differential circuit, the variation of the current referred to the current transformer secondary shall be in the range from 50 % (0.5 A for 1 A CT and 2.5 A for 5 A CT) up to a maximum of 110 % (1.1 A for 1 A CT and 5.5 A for 5 A CT). We request you to kindly consider this factor while choosing the layout of the transformer.

Please check by means of the following formula the correctness of your data: $S = U \cdot I \cdot \sqrt{3}$

Technical data subject to change without notice !

Setting-list XD1-T

Project: SEG job.-no.:

Function group: = Location: + Relay code: -

Relay functions: Date:

Setting of parameters

Function		Unit	Default settings	Actual settings
Id1	Differential current 1	% In	5	
Id2	Differential current 2	% In	5	



**AvK Generátory s.r.o.
ul. 4. května 175
755 01 Vsetín (Czech Republic)**

**Tel.: +420 571 413 322
<http://www.woodward-seg.cz>
info@woodward-seg.cz**